

# dovetail jig

*Steve Neil's  
dovetail jig*

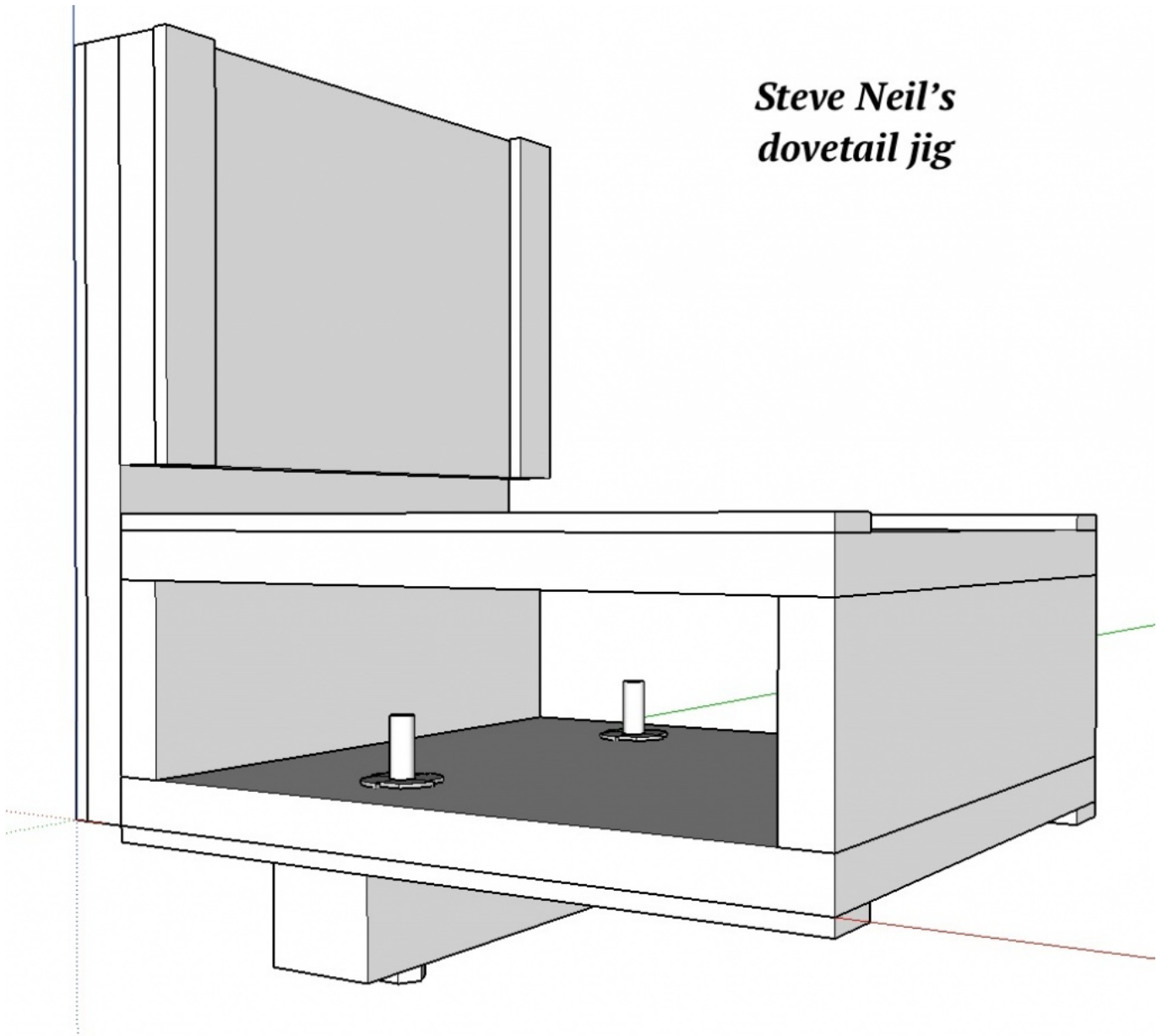

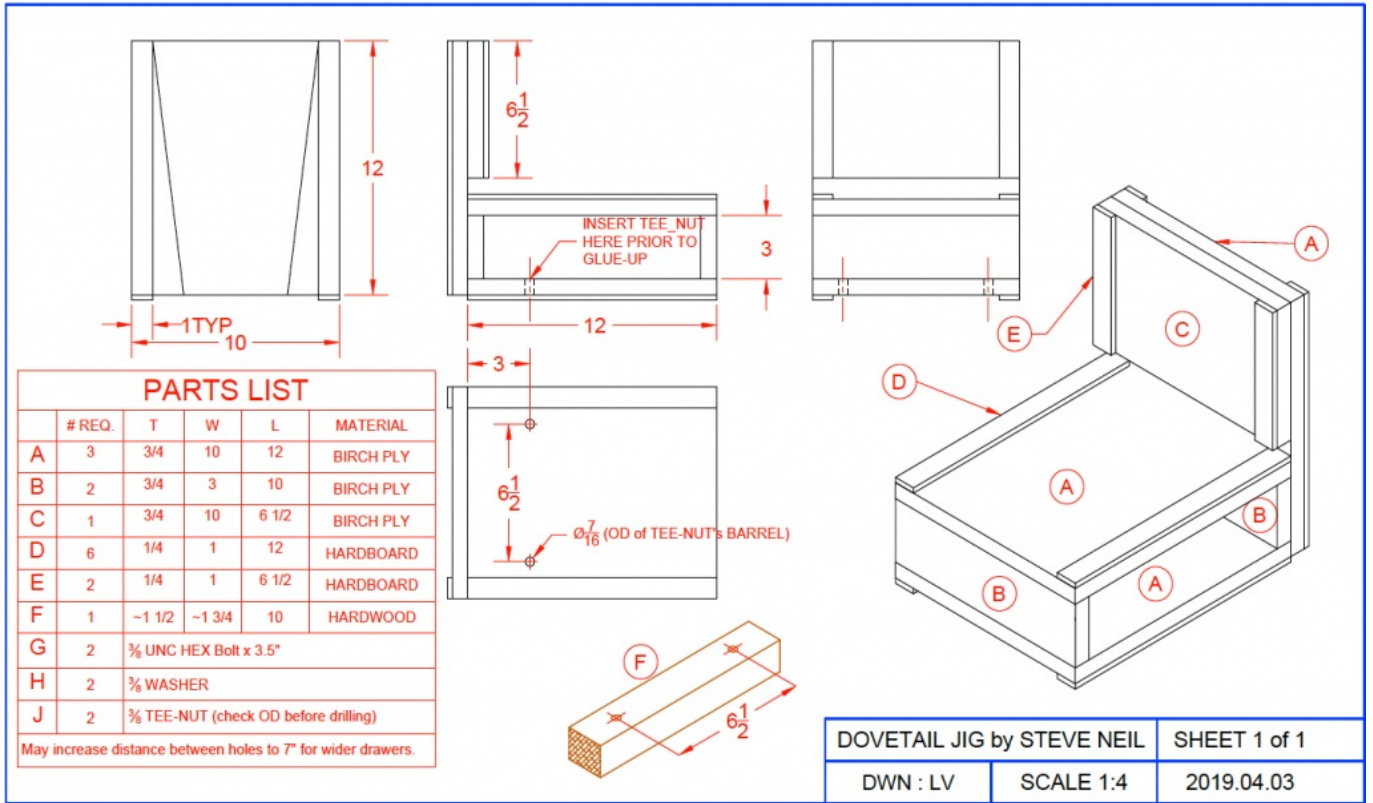

CAD drawing by Larry Vliet

[Printable Version](#)